

SECTION AA

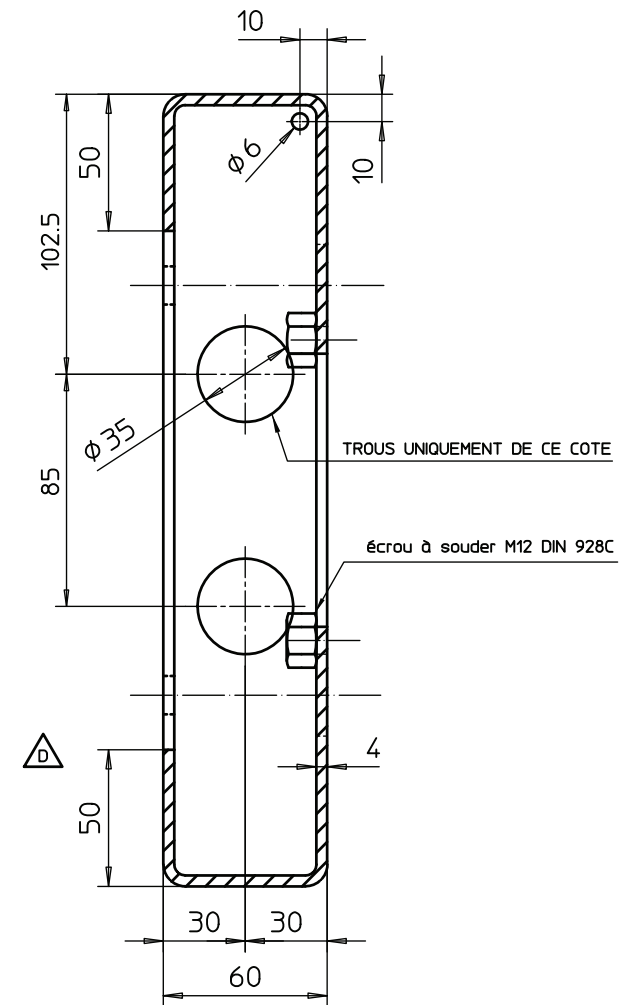

Rem. :peinture NOIR RAL 9005

4*trous diam 16.5(niv inf)
4*trous diam 30 (niv sup)

REM:Souder et poncer tous les raccords

| | | | |
|------|----------------------------|-----------|-----|
| | | | |
| | | | |
| B | AJOUTER 2 TROUS $\phi 35$ | 19 Jun 92 | RK |
| C | $\phi 15$ ---- $\phi 16.5$ | 25 Aug 92 | EB |
| IND. | | DATE | NOM |

| | | | |
|--|--|--|--|
| | | | |
| | | | |
| | | | |
| | | | |
| | | | |
| | | | |

PIECES ANALOGUES

EBARBER & ENLEVER
LES ARETES VIVES

LES DIMENSIONS SONT
DONNEES EN MILLIMETRE

NE PAS MESURER
SUR LE PLAN



| | | | | | | | | | |
|---------------------|-------|---------|-----------------|-----------------------------------|-------------------|--------------------------|-----------|------------|------|
| MATERIE | | | | DESIGNATION | | | | | |
| AC.ST37 ép. 4 mm | | | | SOCLE DE SURELEVATION BL21-STD | | | | | |
| Nb/ap. | Poids | Surface | TOLERANCE GEN.: | TRAITEMENT | FINITION | TECHNIQUE DE FABRICATION | | | |
| | - Kg. | - | ± 0.3 | KH | Peinture à poudre | Forage | | | |
| Automatic Systems | | | | DESSINE | VERIFIE | ECHELLE | DATE | N° PLAN AS | IND. |
| | | | | RK | | 1/2 | 19 Jun 92 | 0002 B 069 | C |